



ATTENTION! READ BEFORE INSTALLING!

FOR BEST VISUAL REPRESENTATION OF YOUR FLOOR

This flooring replicates the look of a natural product which has natural variations in color and texture. For best visual effect, shuffle planks from several cartons and do not install similar boards next to one another.

SUBFLOOR PREPARATION

Subfloor must be level, dry and free of imperfections. An uneven subfloor will make the floor feel unstable and cause premature damage.

Engineered Vinyl Plank Floating Floor Installation Instructions

READ THESE INSTRUCTIONS THOROUGHLY BEFORE BEGINNING INSTALLATION. If the following instructions leave any unanswered questions or if additional information is required, please call ABRAHAM Linc (800-359-5260).

FLOORING MATERIAL SHOULD BE INSPECTED PRIOR TO INSTALLATION

Responsibility for the suitability of Abraham Linc flooring and accompanying products for each individual installation cannot be assumed by Abraham Linc, since Abraham Linc has no control over the installer's proper application. Should an individual plank be doubtful as to appearance or dimension the installer should not use this piece. Abraham Linc will send a replacement in a timely fashion.

NOTE: VINYL PLANKS may be installed with a direct glue-down method on approved wooden (or) concrete substrates that **are on or above grade only.** [Click method may be installed above, on, or below grade.](#) We recommend Moduleo I-Grip or as an option Taylor 2071 that is also approved.

ACCLIMATION

The flooring must be acclimated for a minimum of 72 hours before installation between 65 and 85°F..

READ BEFORE INSTALLING

While the vinyl planks are waterproof, it's not a moisture barrier. It's still a good idea to make sure concrete is cured and tested for moisture and that a moisture barrier is installed in the crawl space. Moisture will not damage the vinyl planks, but it can migrate into the walls and structure of the home. A couple of extra dollars and a few minutes is a small investment for the added protection and peace of mind.

PRE-INSTALLATION JOBSITE REQUIREMENTS

Abraham Linc cannot be held responsible for site conditions.

Carefully examine the flooring prior to installation for color, finish and quality. Ensure adequate lighting for proper inspection. **If flooring is not acceptable, contact your supplier immediately and arrange for replacement.** Abraham Linc cannot accept responsibility for flooring installed with visible defects. Prior to installation of any flooring, the installer must ensure that the jobsite and subfloor meet the requirements of these instructions. Abraham Linc is not responsible for flooring failure resulting from unsatisfactory jobsite and/or subfloor conditions.

Flooring should be one of the last items installed in any new construction or remodel project.

Crawl spaces must be a minimum of 18" (46 cm) from the ground to the underside of the joists. A ground cover of 6–20 mil black polyethylene film is essential as a vapor barrier with joints lapped 6" (15 cm) and sealed with moisture resistant tape. The crawl space should have perimeter venting equal to a minimum of 1.5% of the crawl space square footage. These vents should be open and properly located to foster cross ventilation. Where necessary, local regulations prevail.

PRE-INSTALLATION SUBFLOOR REQUIREMENTS

All Subfloors must be:

- Dry

- Structurally sound
- Clean: Thoroughly swept and free of all debris
- Level: Flat to 3/16" per 10-foot radius

Wood subfloors must be dry and well secured. Nail or screw every 6" along joists to avoid squeaking. If not level, sand down high spots and fill low spots with a Portland Based leveling patch.

Concrete subfloors must be fully cured, at least 60 days old, and should have minimum 6-mil polyfilm between concrete and ground. Subfloor should be flat and level within 3/16" per 10' radius. If necessary grind high spots down and level low spots with a Portland leveling compound.

Ceramic Tile, resilient tile and sheet vinyl must be well-bonded to subfloor, in good condition, clean and level. Do not sand existing vinyl floors, as they may contain asbestos.

INSTALLATION TOOLS

For all installation methods:

- Tape measure
- Tapping block (trimmed piece of flooring)
- Pencil
- Pry bar or pull bar
- Chalk line
- Crosscut power saw
- 3M Scotch-Blue™ 2080 Tape
- 3/8" spacers

Acceptable subfloor types:

- CDX Underlayment Grade Plywood (at least 1/2" thick); total subfloor must be minimum 3/4" thick.
- Underlayment grade particleboard
- OSB (at least 3/4" thick)
- Concrete slab
- Existing wood floor, nailed hardwood, no floating floors.
- Ceramic tile (skim coat grout joints)
- Resilient tile & sheet vinyl one layer thick; (no cushion-backed vinyl).

INSTALLATION INSTRUCTIONS

Inspection: Prior to installation, inspect material in daylight for visible faults/damage. Check if subfloor/site conditions comply with the specifications described in these instructions. If you are not satisfied, do not install, and contact your supplier.

Before laying: Measure the room at right angle to the direction of the flooring. For the best visual effect, planks or tiles in the final row should be at least at least 1/3 the width of the plank or tile. For this purpose, planks or tiles in the first row can be cut to smaller size. Shuffle boards in order to obtain a pleasant blend of shades mixing three to four cartons for blending. Lay boards, preferably following the direction of the main source of light. We recommend laying on wooden floors crossways to the existing floorboards.

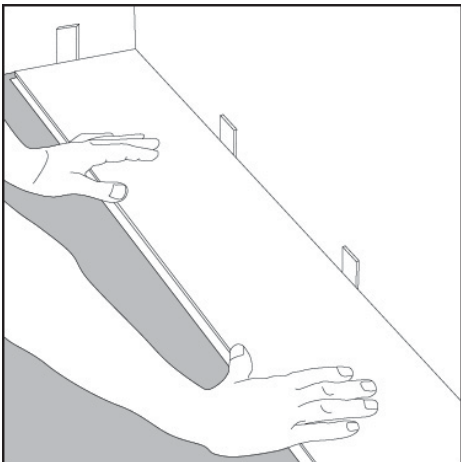

Step 1: Begin installation working from left to right. Insert spacers at ends and edges where planks meet wall.

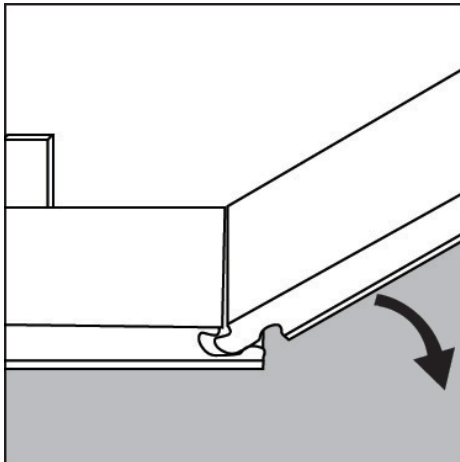

Step 2: Lock short end of plank by inserting tongue into groove at an angle and drop in place. Continue to end of first row.

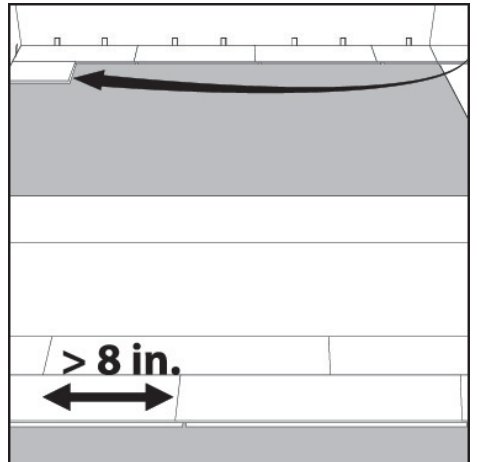

Step 3: Use left over plank at least 8" long to start next row. Planks should be staggered 12" apart.

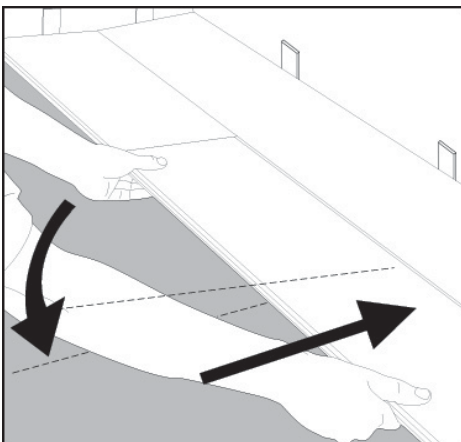

Step 4: Lock long edge of plank by inserting tongue into groove at an angle and drop in place. Slide plank toward end of previously installed plank until the tongue just touches the groove.

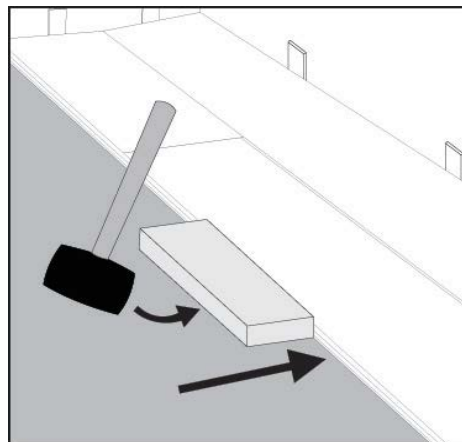

Step 5: IMPORTANT! Use hammer and tapping block to tap long edge of plank to ensure a tight fit. **ANY GAPPING CAN COMPROMISE THE LOCKING SYSTEM!**

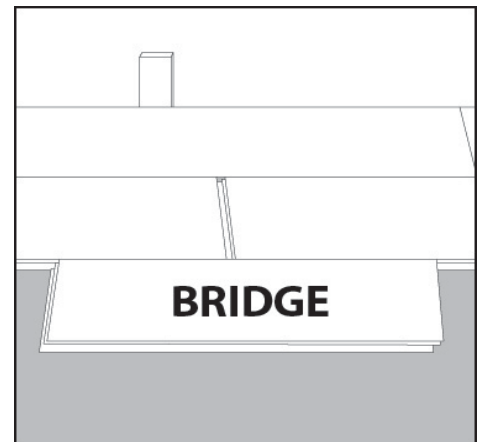

Step 6: Attach a scrap piece of floor to bridge gap between boards.

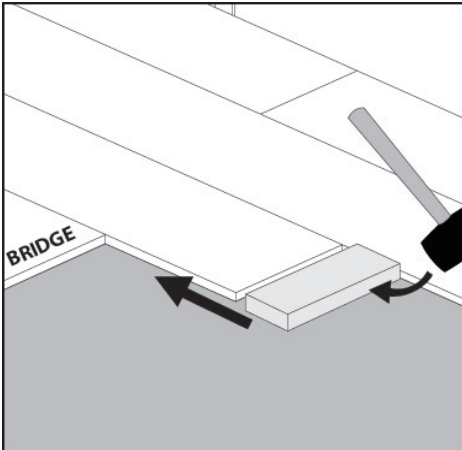

Step 7: Tap end of plank with hammer and tapping block to lock ends of planks together. Remove bridge and continue towards wall until installing the final plank in the row. **BE SURE TO TAP ON EDGE OF VINYL SO AS NOT TO DAMAGE LOCKING PROFILE.**

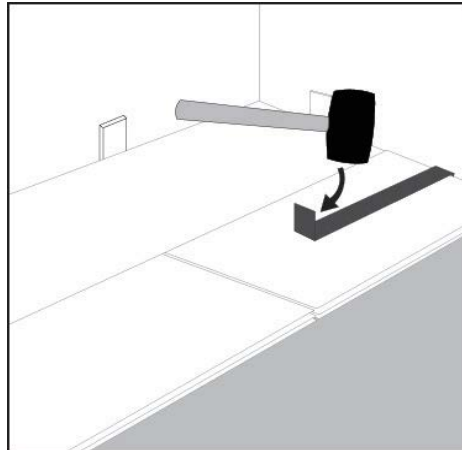

Step 8: Use hammer and pull bar to lock final piece in row. Insert spacer at end of row. Continue installation to final row.

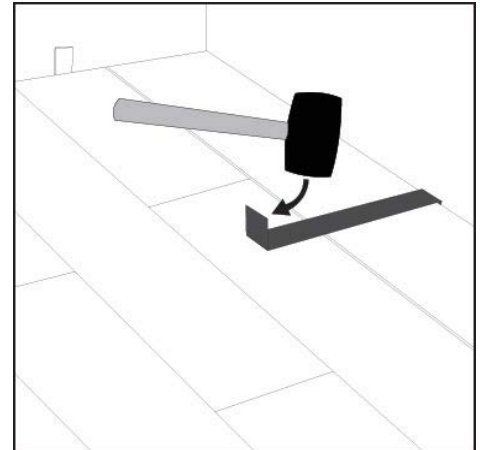

Step 9: Use hammer and pull bar to lock long edges of planks on final row.

INSTALLING UNDER DOOR JAMB

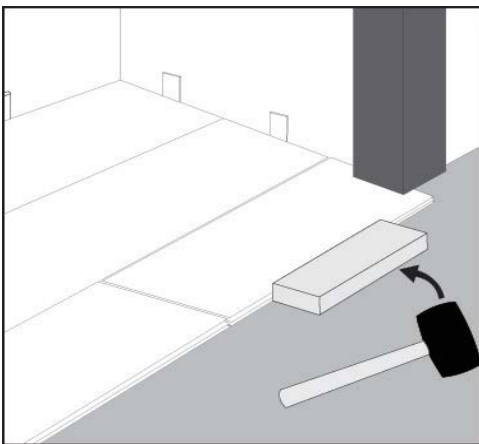

Step 1: Undercut space under door jamb to allow plank to slide freely. Tap long edge with hammer and tapping block to lock long edge.

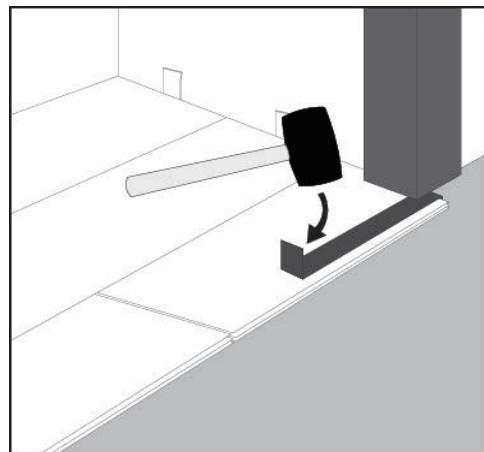

Step 2: Use hammer and pull bar to lock short end of plank.

GLUE DOWN INSTALLATION

One of the key features of Vinyl Planks is the ease and speed with which they install as a glueless floating floor. However, there are instances where the customer may wish to install these floors using the direct glue down method. In addition, there are three instances where Abraham Linc requires that ENGINEERED VINYL PLANKS be installed using the direct glue down method:

- **When installing engineered vinyl planks in areas, such as sun rooms.**
- **Where the floor is exposed to strong direct sunlight, High heat exposure will result in dimensional stability changes causing distortions to all LVT flooring.**
- **Rolling traffic such as but not limited to wheel chairs, ramps, or sloped walk areas.**

ACCLIMATION

ROOM AND FLOORING TEMPERATURES SHOULD BE MAINTAINED WITHIN NORMAL LIVING CONDITIONS BETWEEN 65°F TO 85°F 72 HOURS BEFORE, DURING, AND CONTINUED AFTER INSTALLATION.

When installing ENGINEERED VINYL PLANKS using the glue down method, Moduleo I-Grip LVT Adhesive or as an option Taylor 2071 adhesive should be used and applied to the subfloor using adhesive manufacturer's recommended trowel. Surfaces must be clean, dry and smooth, free of voids, projections, loose materials, oil, grease, sealers, and all other surface contaminants. Maximum floor variation is 1/8" in 10'. Concrete slabs requiring patching or leveling should be repaired with Portland cement based material.

Adhesive instructions should be followed completely.

When employing the direct glue down installation method, DO NOT include a 6-mil polyfilm vapor barrier in the assembly. Flooring material must be adhered directly to the subfloor. Flooring should NEVER be glued to a polyfilm vapor barrier.

IN-FLOOR RADIANT HEAT:

Vinyl Planks can be installed over in-floor or embedded radiant heat systems using the floating or glue down method. When gluing floor, use Moduleo I-Grip Adhesive or as an option Taylor 2071 Adhesive, and follow manufacturer's recommended instructions.

- Turn the heat off for 24 hours before, during and 24 hours after installation when installing over radiant heated subfloors.
- Failure to turn the heat off may result in significantly shortened working time of the adhesive
- Floor temperature must not exceed 85°F (30°C).
- Once the installation has been completed, the heating system should be turned on and increased gradually (in increments of 5° F) until returning to normal operating conditions not to exceed 85°F (30° C).
- Failure to strictly follow adhesive manufacturer's guidelines may result in failure and void the warranty.

Warning: Electric heating mats that are not embedded into the subfloor are not recommended for use underneath Vinyl Planks. Using electric heating mats that are not embedded and applied directly underneath Vinyl Planks could void the warranty for your floor in case of failure. It is best to install Vinyl Planks over embedded radiant floor heating systems and adhere to the guidelines listed above.

EXPANSION GAP REQUIREMENTS:

Rooms that are greater than 30' in length and/or 25' in width must have T-mold expansion properly installed. Always maintain a minimum of 3/8" expansion gap around all vertical obstructions including doorjamb. Doorways less than 36" must have a T-mold installed for expansion between rooms.

SOUND TRANSMISSION UNDERLAYMENT

For Impact Insulation Class (IIC) and Sound Transmission Class (STC) requirements by International Building Codes (IBC), an approved underlayment for LVT may be installed according to the manufacturer's installation requirements.

AFTER INSTALLATION

- Flooring should be one of the last items installed in a project. In order to protect the floors while other trades are finishing their work prior to final cleanup and turnover to the owner, use rosin paper and only use 3M Scotch-Blue™ 2080 Tape to hold the rosin paper to the floor (other blue tapes may damage the finish). Clean the floor thoroughly before laying the rosin paper to ensure that no debris is trapped underneath. DO NOT USE plastic film or other non-breathing coverings as this can cause the floor to become damaged from humidity buildups.
- Dust mop or vacuum your floor to remove any dirt or debris.
- It is suggested that you buff the floor with lamb's wool pads in order to remove any loose splinters, residues, foot prints, etc.

Protection and Maintenance of Your Floor

Lasting beauty can be achieved through purchasing a quality floor covering and providing proper on-going maintenance.

- Furniture should be moved onto the newly installed floor using an appliance hand truck over hardboard runways.
- **Avoid exposure to long periods of direct sunlight.** Close blinds or drapes during peak sunlight hours. Floor covering subjected to excessive heat and light is subject to thermal degradation and, in the case of engineered vinyl planks, to changes in dimensional stability. Use appropriate precautions to minimize potential effects on the floor covering.
- Oil or petroleum-based products can result in surface staining. Do not track asphalt-driveway sealer or automobile-oil drips onto the vinyl floor covering.
- Use non-staining mats. Rubber may discolor the floor.
- Frequently moved furniture should be equipped with felt pads to avoid scratching the floor. Heavy furniture and appliances should be equipped with non-staining large surface floor protectors. Furniture with castors or wheels must be easy swiveling, large surface non-staining and suitable for resilient floors. Do NOT use ball type castors as they can damage the floor.
- Use floor protectors under furniture.
- Use walk off mats at entrances to prevent dirt and grit from being tracked on to the floor.
- Sweep or vacuum the floor regularly to remove loose dirt. Do NOT use vacuums that use a beater bar or turn beater bar off.
- Do NOT use electric brooms with hard plastic bottoms with no padding.
- Clean up spills immediately.
- Damp mop as needed using clean water and a neutral pH diluted floor cleaner. Do NOT use harsh cleaners or chemicals on the floor. Do NOT use abrasive scrubbing tools. Do NOT use detergents, abrasive cleaners or "mop and shine" products.
- Vinyl Flooring, like other types of smooth floors, may become slippery when wet. Allow time for floor to dry after washing. Immediately wipe up wet areas from spills, foreign substances or wet feet.
- Dogs and other domestic indoor pets should have nails trimmed to avoid scratches.